

## **AM5K COMBINED DEPTH/TENSION MEASUREMENT DEVICE**

**AM5KA514 (one encoder, no MMD)**  
**AM5KA515 (two encoders, no MMD)**  
**AM5KA516 (two encoders, no MMD, Deep Groove tension)**  
**AM5KA523 (two 1200 PPR encoders, MMD)**  
**AM5KA536 (two 300 PPR encoders, MMD)**

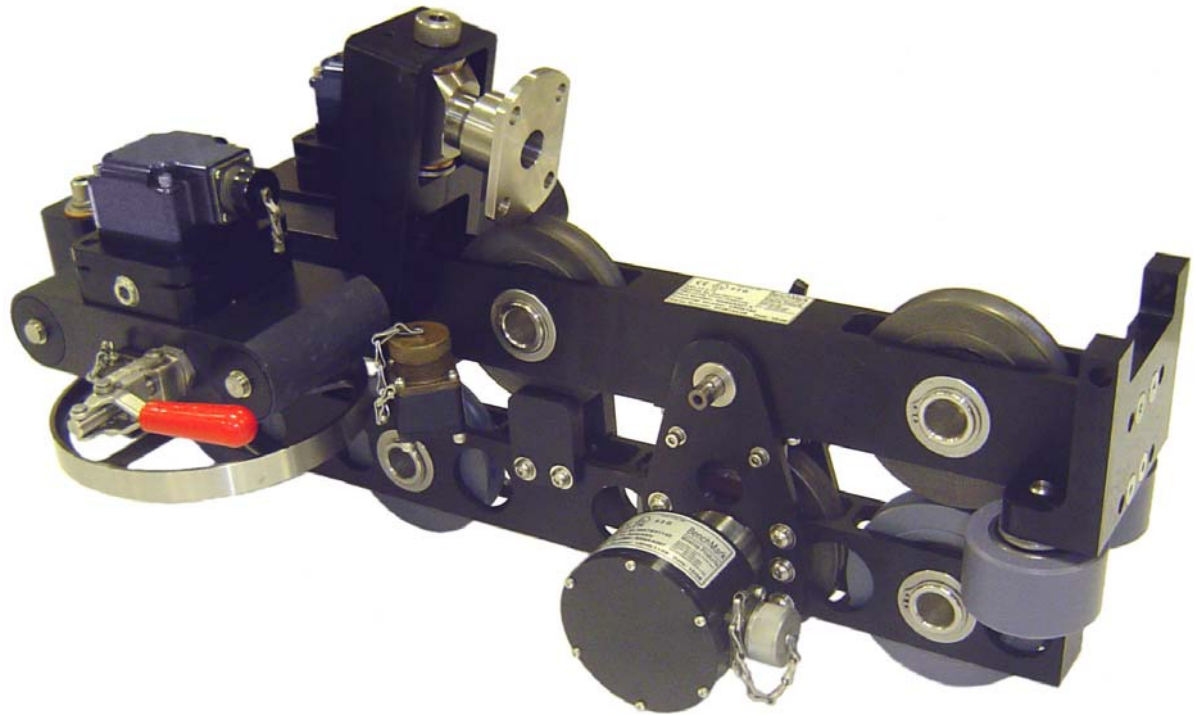

### **CONTENTS**

<b>1.0</b>	<b>GENERAL</b>
<b>2.0</b>	<b>SYSTEM DESCRIPTION</b>
<b>3.0</b>	<b>OPERATION</b>
<b>4.0</b>	<b>MAINTENANCE AND REPAIR</b>
<b>5.0</b>	<b>RECOMMENDED SPARE PARTS</b>
<b>6.0</b>	<b>DRAWINGS AND PARTS LISTS</b>
<b>6.1</b>	<b>Measure Head Assembly</b>
<b>6.2</b>	<b>Magnetic Mark Detector</b>
<b>6.3</b>	<b>Load Pin</b>
<b>6.4</b>	<b>Encoder</b>
<b>6.5</b>	<b>Backup Odometer</b>

## **1.0 GENERAL**

The AM5K Wireline Measuring Device is a compact and lightweight device for measuring both wireline depth and tension. The device is designed to be mounted to the spooling arm of a wireline unit. It is unique to other measuring devices in that it measures both depth and tension on wireline cables from .190" to .494". This device will work on both open and cased hole wireline units which allows standardization on a measuring head for all types of operations.

### **FEATURES AND BENEFITS:**

- **Straight-line measurement (cable sizes can be changed without affecting measurement)**
- **Dual Tangential Measuring Wheels made from specially hardened steel**
- **Accepts cable sizes from .190" to .494" diameter (4.8 mm to 12.55 mm)**
- **Lightweight design with integral tension makes the device ideal for high angle rigups**
- **Device opens up to provide easy cable installation and removal, by removing a single pin**
- **Includes both horizontal and vertical guide rollers to minimize measuring wheel loading**
- **Rollers are oversized to increase reliability and reduce maintenance**
- **Guide rollers are made from composite material to reduce weight and cable wear**
- **Rear or Center spooling arm mount to minimize head "jerking"**
- **Tension Load Axle and amplifier can be configured for different outputs.**
- **Digital Magnetic Mark Detector**
- **Accepts single or dual encoders**
- **Supports fully independent backup depth measuring system using a magnetic pickup**
- **Backup depth system reduces drag on measuring wheel by eliminating mechanical drive cable**
- **Encoder, Mark Detector, and Tension amplifier certified for Zone II area use**
- **Anodized aluminum frame. All steel parts are plated or SST**

## 2.0 SYSTEM DESCRIPTION

### DEPTH MEASUREMENT:

The AM5K Measuring Head uses dual spring-loaded measuring wheels to measure the amount of wireline moving to and from the borehole. The measuring wheels are coupled to one or two optical encoders that transmit electrical signals via a cable to the hoistman's panel and/or logging computer. An independently powered magnetic encoder is used for back up depth indication.

The hardened measuring wheels are 2.0000 ft. (.609600 m) in circumference. Springs are used to hold the measuring wheels in contact with the wireline. The springs are sized to provide the appropriate friction between the wheels and wireline. The frame members are anodized 6061-T6 aluminum.

Under ideal conditions, without magnetic marks, the measuring heads have an accuracy of +/- 3 m in 3000 m (10 ft in 10,000 ft.). With magnetic marks and accurate line stretch calculations, an accuracy of .3 m in 3000 m (1 ft in 10,000 ft) can be achieved. The Kerr Hoistman's panel is required to fully utilize the Kerr mark detection and stretch correction algorithms.

### TENSION MEASUREMENT:

Power Requirements:	+/-15 vdc power Kerr proprietary circuit board which amplifies the load pin signals and provides a 1.5v differential output. 0vdc = 0lbs, 1.5vdc = 20,000 lbs.	
Temperature stability:	<= .015% full scale / deg F on zero <= .02% full scale / deg F on output	
Accuracy:	Within 150 lbs or 3% of actual, whichever is greater	
Maximum load (tested):	16,000 lbs	7,258 kg
(theoretical):	20,000 lbs	9,072 kg

### GENERAL SPECIFICATIONS:

WEIGHT:	58 lbs	26.3 kg
LENGTH:	26.5"	673 mm
HEIGHT:	10.8"	274 mm
WIDTH:	15.3"	389 mm
MAXIMUM TENSION:	20,000 lbs	9072 kg
MEASURING WHEEL SIZE:	24.000"	609.60 mm
CABLE SIZES:	.190" to .494"	4.8 mm to 12.55mm
CABLE BEND OVER TENSION WHEEL:	2.5 – 7.5 degrees (depends on cable) Minimal or no affects on magnetic marks	

### 3.0 OPERATION

#### 3.1 SPOOLING ARM INSTALLATION – OVERHEAD SPOOLING ARM

Install the measuring head on to the spooling arm by using the top adapter mount assembly to mount to an overhead spooling arm. The mount is designed to mount with a standard U-joint yoke.

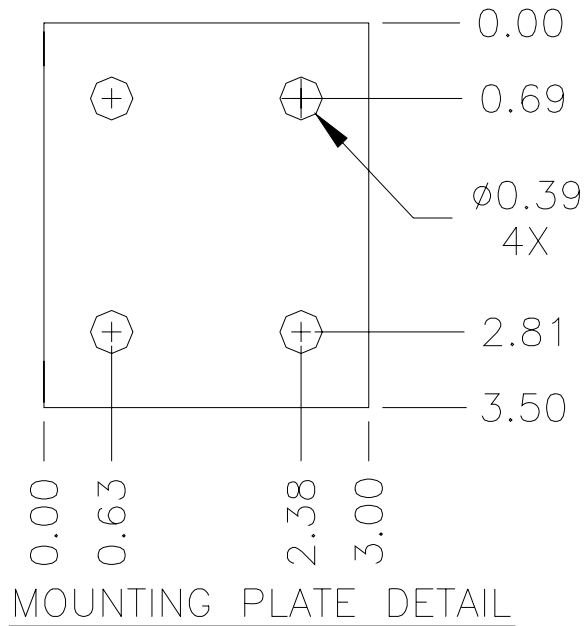

MOUNTING YOKE

Make sure that the head can freely sit on the wireline. If the mounting arrangement will not let the head travel up and down freely and if the cable puts a upward or downward force on the measuring head, this force will cause an offset to the tension measurement which will result in an incorrect tension reading.

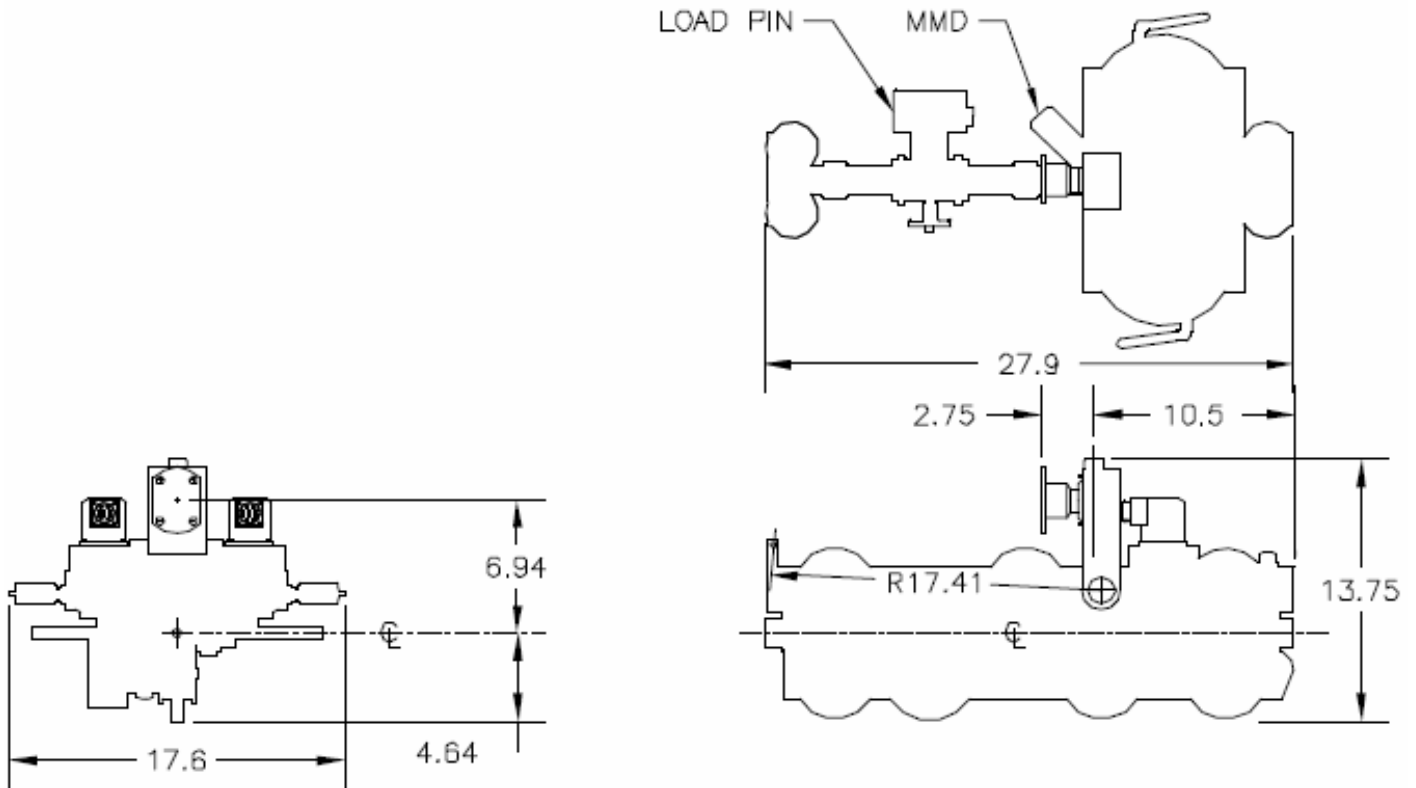

### 3.2 CABLE INSTALLATION

To install cable, first open the wheels by shifting the red release handles.

Next, remove the push pin, and hinge the head open.

Lifting up on the wireline cable makes it easier to remove the push pin.

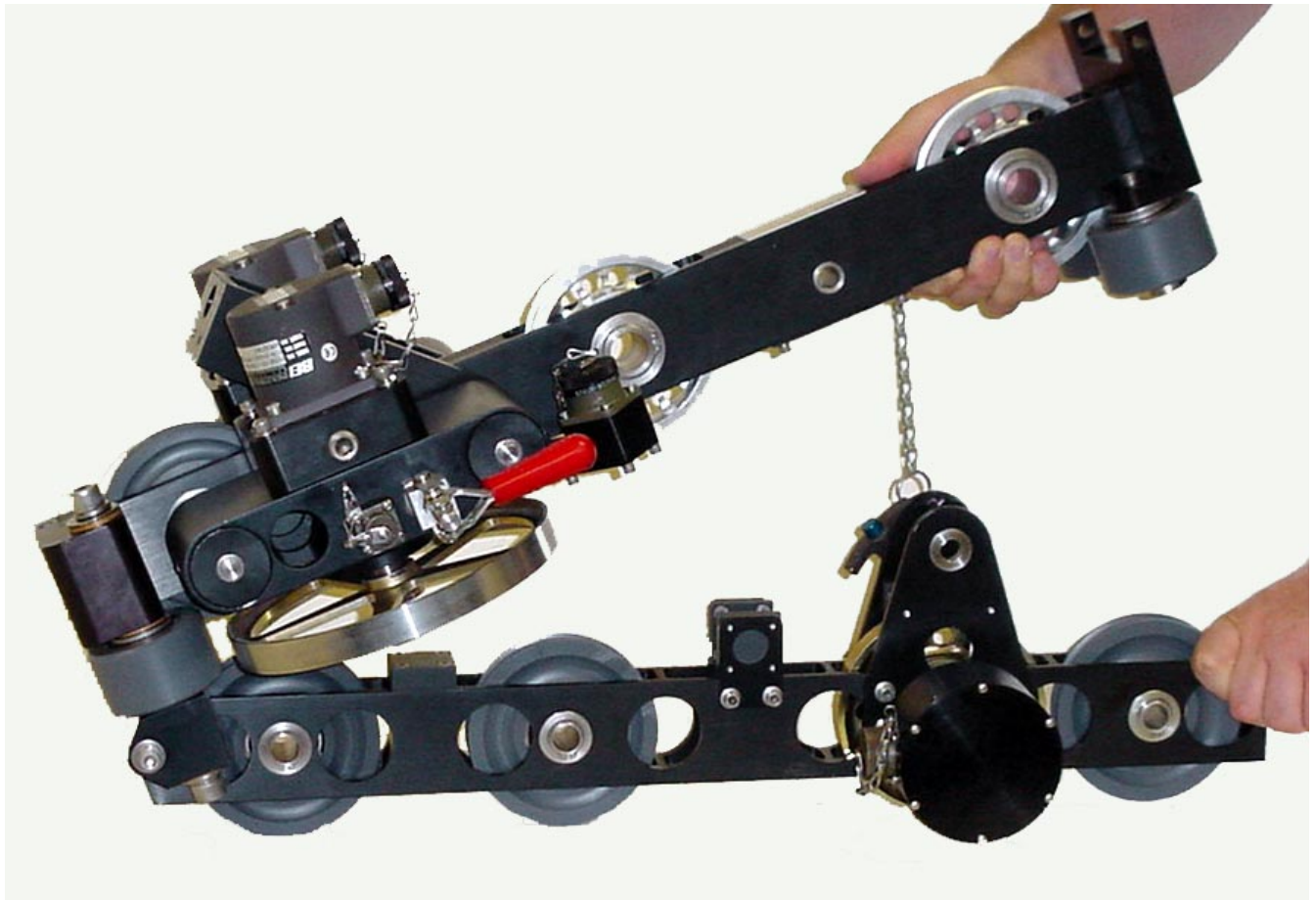

The cable can now be inserted or removed.

Close the red release handles to tighten the wheels against the wireline.

Swing the head closed and reinsert the pin.

### 3.3 CABLE REMOVAL UNDER LOAD

- 3.4.1 If under load, the load will need to be removed from the device prior to removing the retaining pin. A "C-clamp" or a nylon "ratchet strap" can be used to remove the load.
- 3.4.2 Install a C-Clamp across the top and bottom frames as shown in the drawing below. The ratchet strap can be installed in a similar way.

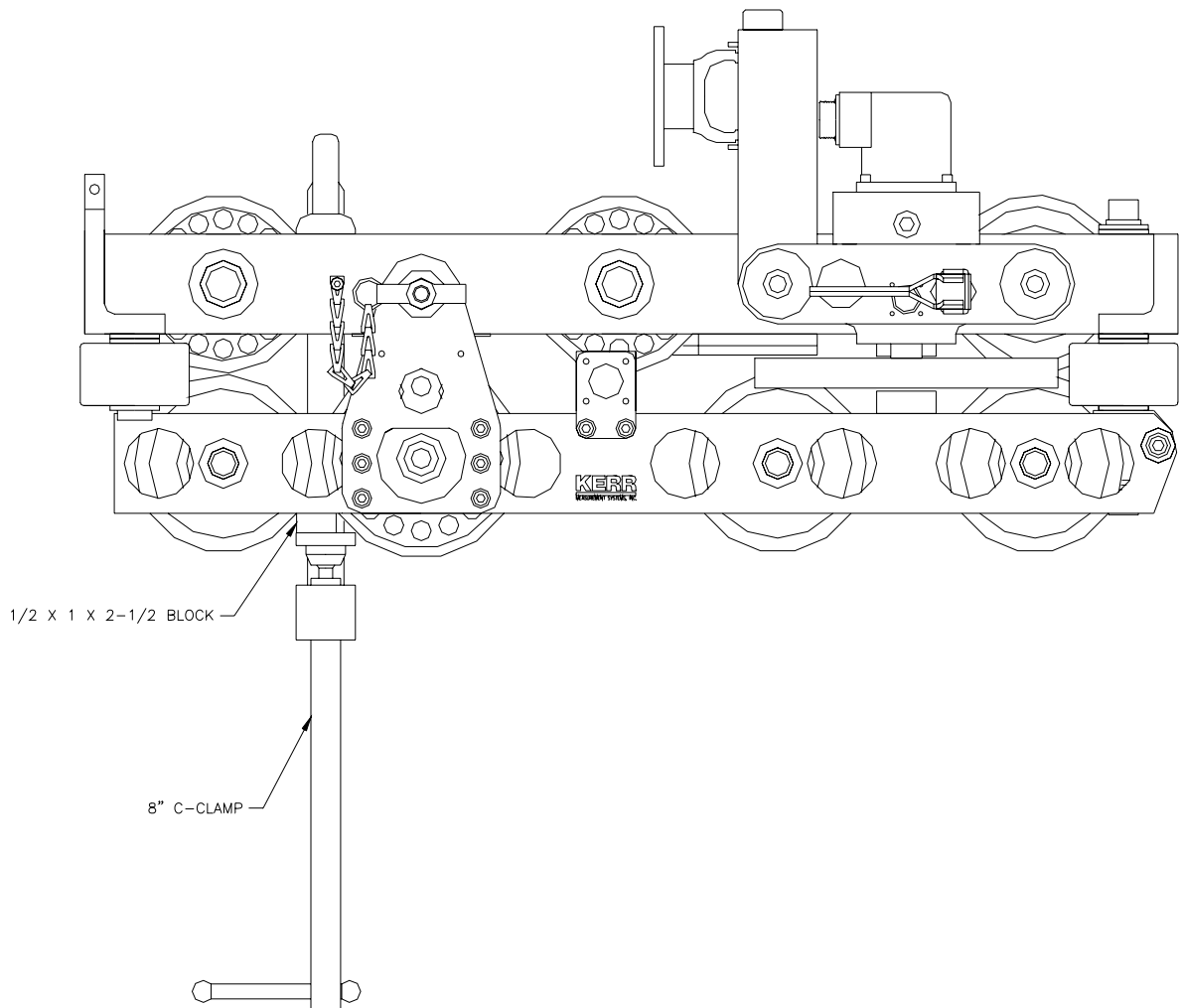

- 3.3.3 Tighten the C Clamp until the load is removed from the retaining pin. Remove the retaining pin then loosen and remove the C Clamp.

### **3.4 CHANGING CONFIGURATION BETWEEN OPEN HOLE AND CASED HOLE**

A measuring head configured for open hole will typically contain a magnetic mark detector and a 2<sup>nd</sup> encoder. Cased hole operations rarely require a magnetic mark detector and typically use only one encoder.

If the head is configured for open hole, no changes are required to run it on a cased hole unit. You may elect to remove the magnetic mark detector if you have no plans to use the head on an open hole unit any time in the near future.

The cased hole head can be configured with a different wear plate. The cased hole wear plate is thicker and stepped on one end to keep the line from riding near the top of the wheels. This can occur when going in the hole with a small cable (7/32") with a very light load. The open hole wear plate is flat. Both plates are made from hardened tool steel. The wear plate is mounted on the upper frame above the measure wheels.

Part number for the open hole wear plate is: AM5KM034

Part number for the cased hole wear plate is: AM5KM074

3.4.1 To remove the magnetic mark detector, refer to item 12 of drawing 6.2. Remove the four screws holding the detector in place then remove the detector. To install a magnetic mark detector, reverse this procedure.

3.4.2 To remove an encoder, remove the four screws securing the encoder adapter to the head. Remove the encoder and adapter. Remove the coupling from the measuring wheel shaft.

### **3.5 INSTALLING THE DEEP GROOVED TENSION WHEEL**

3.5.1 A Deep Groove High Load tension wheel is available for use when line tension greater than 12,000 lbs is commonly encountered. This wheel has a deeper groove to better support the wireline at high tensions. The deep groove also reduces the radius of the wheel which lowers the bend angle of the wireline.

This wheel is only for use with .472 Slammer or .494 Super Slammer cables and cannot be used with smaller cable sizes. For cables larger than .472, the severe load tension wheel should be used.

The normal wheel can be used at high loads for short pull durations but should not be used when loads exceed 12,000 lbs for an extended period of time.

3.5.2 To install the High Load tension wheel, replace the standard shallow grooved tension wheel with the deep grooved tension wheel. The load pin does not need to be changed. The High Load tension wheel can be ordered from Kerr Measurement Systems Inc. by part number AM5KA073. This kit includes the Tension Wheel, and bearing. It can easily be installed in the field.

Ensure that the slot in the bushing of the tension wheel is aligned with the roll pin on the side of the frame. The roll pin is only installed on one side of the frame and it needs to be inserted in the slot.



**DEEP GROOVED HIGH TENSION WHEEL**



**STANDARD SHALLOW GROOVED TENSION WHEEL**

### 3.6 SYSTEM OPERATION

- 3.6.1 Determine cable size to be used – .484" to .190". Since the wireline cable actually bends around the tension wheel, the bend radius of the wireline cable will affect the tension measurement.
- 3.6.2 Enter tension calibrate factor. These corrections are automatically made in the BenchMark hoistman's panel by selecting the proper cable size using the menu. If a different panel is used, enter the tension factor at this time.

Tension Multiplier	<u>VALUE</u>	<u>CABLE SIZE</u>
	.9	.484
	1	.472
	1.1	7/16"
	1.2	3/8"
	1.4	5/16"
	1.5	9/32"
	1.8	7/32"

#### Load Cell Angle

- Standard Flat Tension Wheel = 0
- .472 cable with Severe Load (grooved) Tension Wheel = 128
- .490 cable with Severe Load (grooved) Tension Wheel = 121

- 3.6.3 Install line in measuring head. (refer to section 3.2)
- 3.6.4 Make sure line is laying slack and head is free to move. Press the Ten Zero Cal button and tension value should read 0.
- 3.6.5 Press the Zero Depth button to set the depth to zero when the tool is hanging at the zero point.
- 3.6.6 Simultaneously press the enable and zero button on the backup display panel at this time to set its zero.
- 3.6.7 At this point, the system is ready to log. Watch for visual indications of problems such as excessive vibration, wheel or roller slippage or lockups that signify bearing or shaft failures, or cable tracking problems.

## **4.0 MAINTENANCE AND REPAIR**

### **4.1 PRE-JOB CHECK**

Each time the system is used perform the following steps:

Verify that the AM5K is properly and securely attached to the spooling arm. Several different mounting kits are available for different types of spooling arms.

Verify that the depth measuring wheels are clean and that no groove has been worn into the measuring wheel surface. Check the measuring and guide wheels for looseness, play, out-of-roundness, worn or rough sounding bearings, or other mechanical conditions that could affect measurement accuracy. Ensure that the wheel bearings inner race is not spinning on the shaft and that the shaft is not spinning in the bushings.

Verify that all fasteners are tight and that the ball lock pushpin is secure. Verify that the encoder, electronic load pin, and backup counter cable are installed and properly routed. Verify that the depth system is working by turning the wheel and observing the hoistman's panel and backup display unit to indicate cable movement. The hoistman's panel and backup display should measure 2' for each rotation of the wheel. If more than one encoder is installed check both encoders by turning each wheel and verifying that the hoistman's panel will read 2' for each rotation of either wheel.

### **4.2 POST-JOB MAINTENANCE**

At the completion of each job, thoroughly clean and dry the device as soon as possible. This avoids problems caused from borehole residues transferred from the wireline onto the measuring device. Borehole residues should be washed from the device with a cleaning solvent such as Varsol or an equivalent type. Rinse the device with water, dry, and wipe down with an oily rag.

**Do not pressure wash**

### 4.3 MONTHLY MAINTENANCE

Visually inspect the interiors of the electrical connectors for the encoders and electronic load axle for dirt and evidence of insulation breakdown. Clean or replace as necessary. Install dust caps on the connectors if the cables are removed.

Manually rotate each wheel by hand to verify its condition. Inspect the depth measuring wheels for signs of abnormal wear, diameter changes, or shaft/bearing play that can affect measurement accuracy. The wheel should be replaced if it is grooved more than .005". The wheel should be 7.639 / 7.640" (194 mm) in diameter with a 24" circumference (609.6 mm).

Inspect the tension wheel for signs of abnormal wear, diameter changes, or shaft and bearing play that could affect measurement accuracy. It should be replaced if it is grooved more than .030". The flat tension wheel should be 5" (127 mm) in diameter. The grooved tension wheel (severe load) should be 4.375" in diameter (bottom of groove).

Inspect the two grooved guide wheels on either side of the tension wheel. They should be 4" (101.6 mm) in diameter (bottom of groove).

Grease all the wheels and bearings that are fitted with a grease fitting (see following diagram). Use a water proof, marine grade grease. An inverted grease nozzle (Kerr p/n AM5KP130) is supplied with each head. This nozzle will fit any standard grease gun.

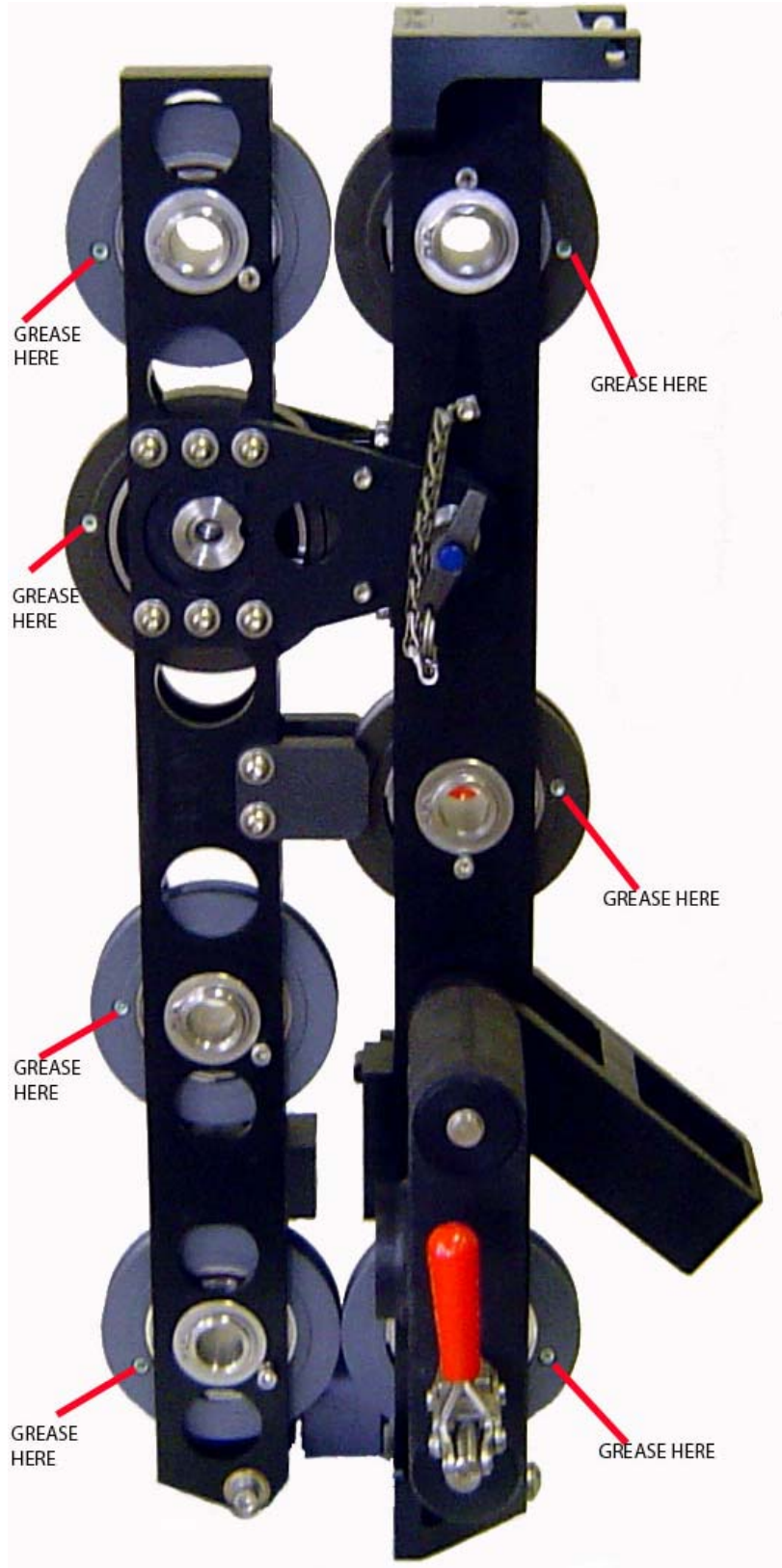

## 4.4 ASSEMBLY / DISASSEMBLY PROCEDURES

### 4.4.1 MEASURING WHEEL, SHAFT, AND BEARING REMOVAL

Either measuring wheel can be removed from the measuring head. First shift the red release handle to move the wheel away from the frame. Next remove the encoder with its adapter.

On the later model heads, the wheels (item 22) are keyed onto the shaft and can be removed simply by removing the screw holding the wheel to the shaft (item 85). On earlier model heads, the wheels are pressed on to the shaft. The lower snap ring between the wheel and the bearing must first be removed. Pull the wheel and shaft from the mount. Reassemble in the opposite order. The bearings (item 56) should also be replaced at this time.

### 4.4.2 ENCODER AND ENCODER COUPLING INSTALLATION

To install the encoder coupling, first remove the plug in the encoder adapter. Install one of the metal parts of the three piece coupling (item 36) to the wheel shaft and tighten it using a hex wrench. Next, install the center plastic piece of the coupling onto the wheel shaft coupling. Place the other metal coupling on the encoder shaft and set the encoder on the mount. Snug up the encoder coupling then remove the encoder and tighten the coupling. Reinstall the encoder with o-rings (item 98) and tighten it to the encoder mount (item 6). Next tighten the plug.

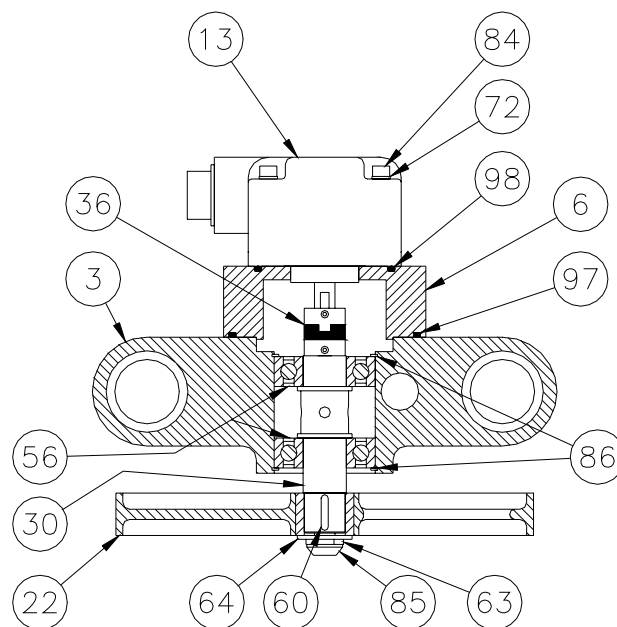

#### **4.4.3 ELECTRONIC LOAD PIN REMOVAL**

The electronic load pin is held in place by one retaining ring on the outer end of its shaft. Remove the retaining ring. The load pin can then be removed from the mounting frame.

#### **4.4.4 BACKUP DEPTH MAGNETIC PICKUP REMOVAL AND INSTALLATION**

The backup depth magnetic pickup is mounted to the encoder adapter. It is held in place by four screws. Remove the screws and the pickup can then be removed. The pickup must be properly oriented to work correctly. The slot should be oriented to the top. The top side is the encoder side. Ensure that an o-ring is inserted between the plastic housing and the mount. An additional o-ring is used between the connector and the housing to keep moisture out.

If the backup display is counting backward (i.e. counting negative when going downhole), simply rotate the pickup 180 degrees to change the direction.

#### **4.4.5 ENCODER MOUNT REMOVAL**

Follow these steps to remove the encoder mounts.

1. Using a pair of vice grips, grab the end of the pin and pull on it (see photo).



2. Use a screw driver to capture the end of the spring (see photo).



3. The end cap and the pin can now be removed (see Photo)

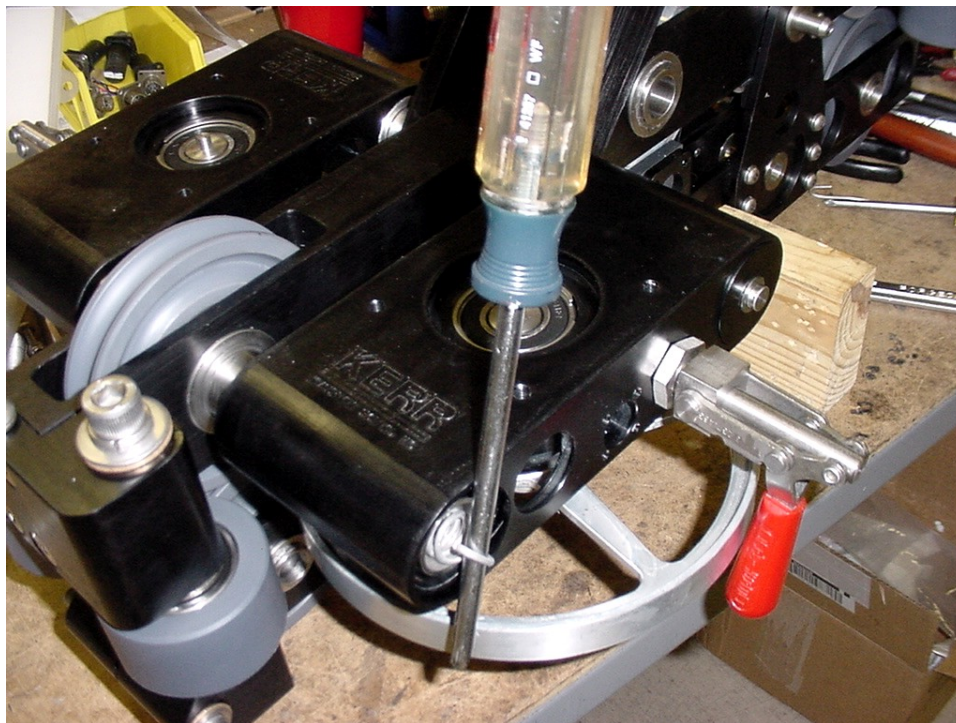

4. Use a hook to pull the spring out far enough to remove the screwdriver (Careful not to bend the spring).
5. Remove the floating encoder assembly.

6. Repeat for the other side.
7. Remove anti-rotation screw (if equipped).
8. Remove snap ring and pull out sliding shaft.
9. Remove the wheel assembly.
10. Re-assemble in reverse order.

#### **4.4.6 INSTALLING THE LOAD AXLE WHEEL**

1. Insert the tension wheel into the frame. Make sure the slotted hole in the tension wheel bushing is on the same side as the roll pin hole in the frame.

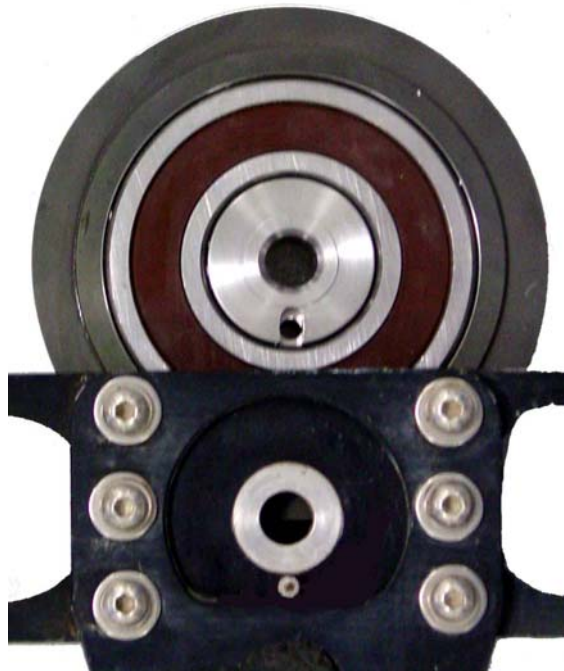

2. Use a bolt in place of the load pin to hold it in place. Install an allen wrench or other long tool to align the hole in the bearing with the slotted hole in the frame.

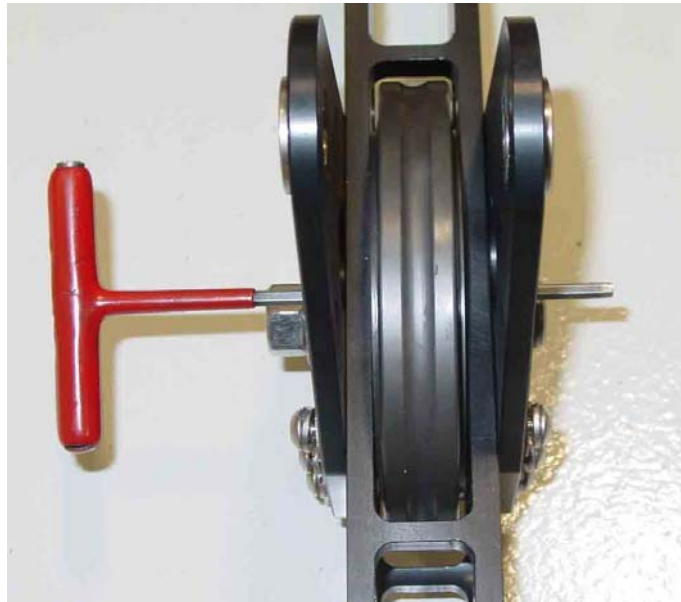
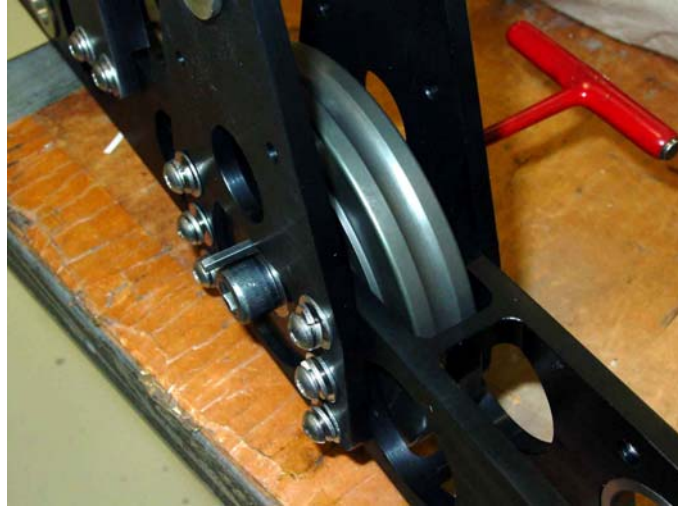

3. Insert a 3/16" x 1/2" long roll pin into the hole. Do not use a longer roll pin as it will put the wheel into a bind.



4. Drive the roll pin flush. Make sure that the wheel can freely slide up and down.



5. Remove the bolt and install the load pin.

## 5.0 RECOMMENDED SPARE PARTS

It is recommended that the following list of parts be kept on hand for remote locations.

ITEM	PART NUM	DESCRIPTION	QTY	REF
13	AMASLP061	ENCODER HD2.5D-0-SS-37F-1200-	1	
14	AM5KA055	ASSY ENCODER BACKUP MAGNETIC	1	OPTION
22	AM5KM001	WHEEL MEASURING 2FT 5 SPOKE	2	
31	AM5KA137	ASSY WHEEL GUIDE PLAS 35MM BRG	4	
33	AM5KA073	ASSY WHEEL TENSN GRV LOAD AXLE	1	OPTION (HI TENSION)
34	AM5KA164	ASSY WHEEL TENSN FIXD 35MM BRG	2	
35	AM5KA065	ASSY ROLLER SPOOLNG 2.75" PLAS	4	
36	AM5KM073	COUPLING MOD ENCDR 0.250/0.375	2	OPTION
51	AMS1P009	RETAINING PIN (T HANDLE)	1	
54	AM5KM157	BEARING BALL 35MM ID MOD	6	
55	AM5KP088	BEARING LINEAR 30MMID X 40MMOD	8	
56	C276P002	BEARING BALL 20MM FAFNIR 204PP	4	
58	AM5KM134	BEARING BALL 40MM ID MOD	1	
59	AM5KP001	CLAMP TOGGLE PUSH/PULL SST	1	
101	AM5KP130	NOZZLE GREASE FITTNG FLUSH	1	

## 6.0 DRAWINGS AND PARTS LISTS

### 6.1 MEASURE HEAD ASSEMBLY

#### SIDE VIEW

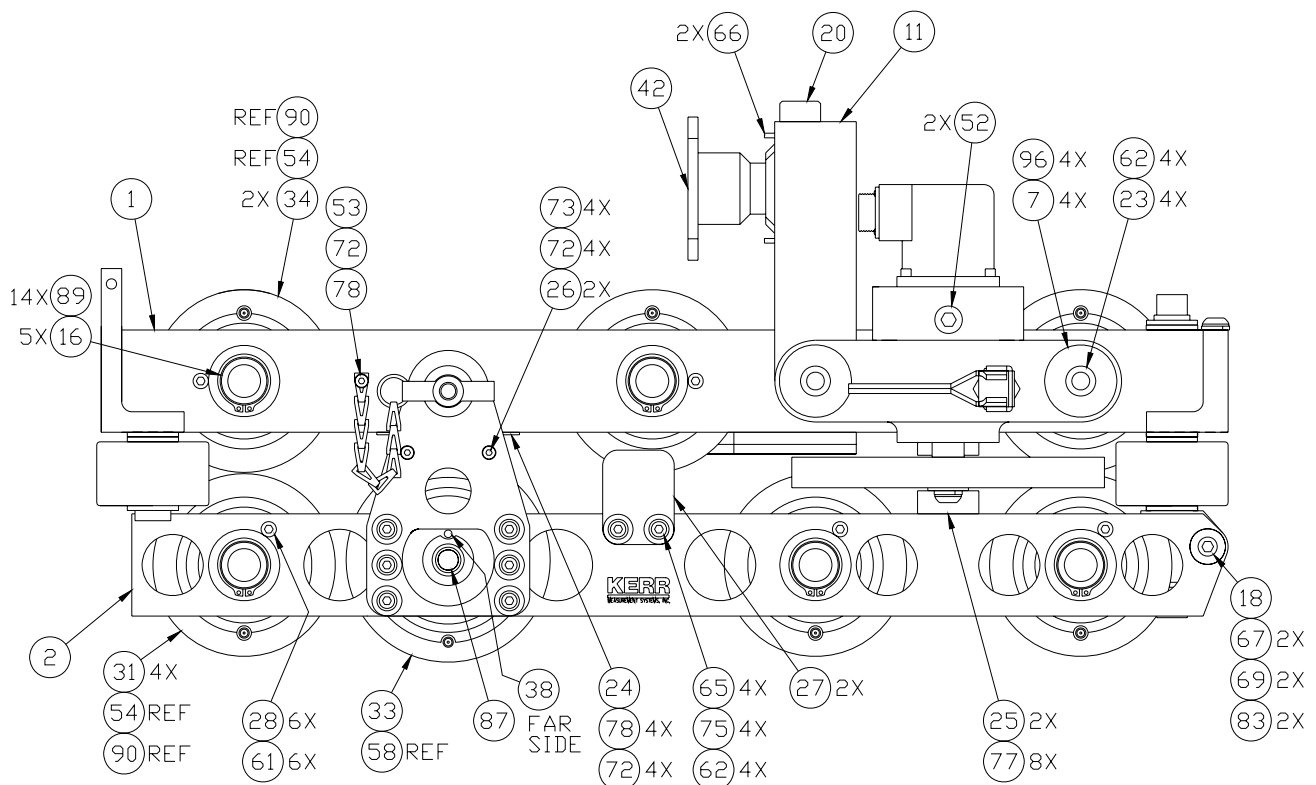

**TOP VIEW**

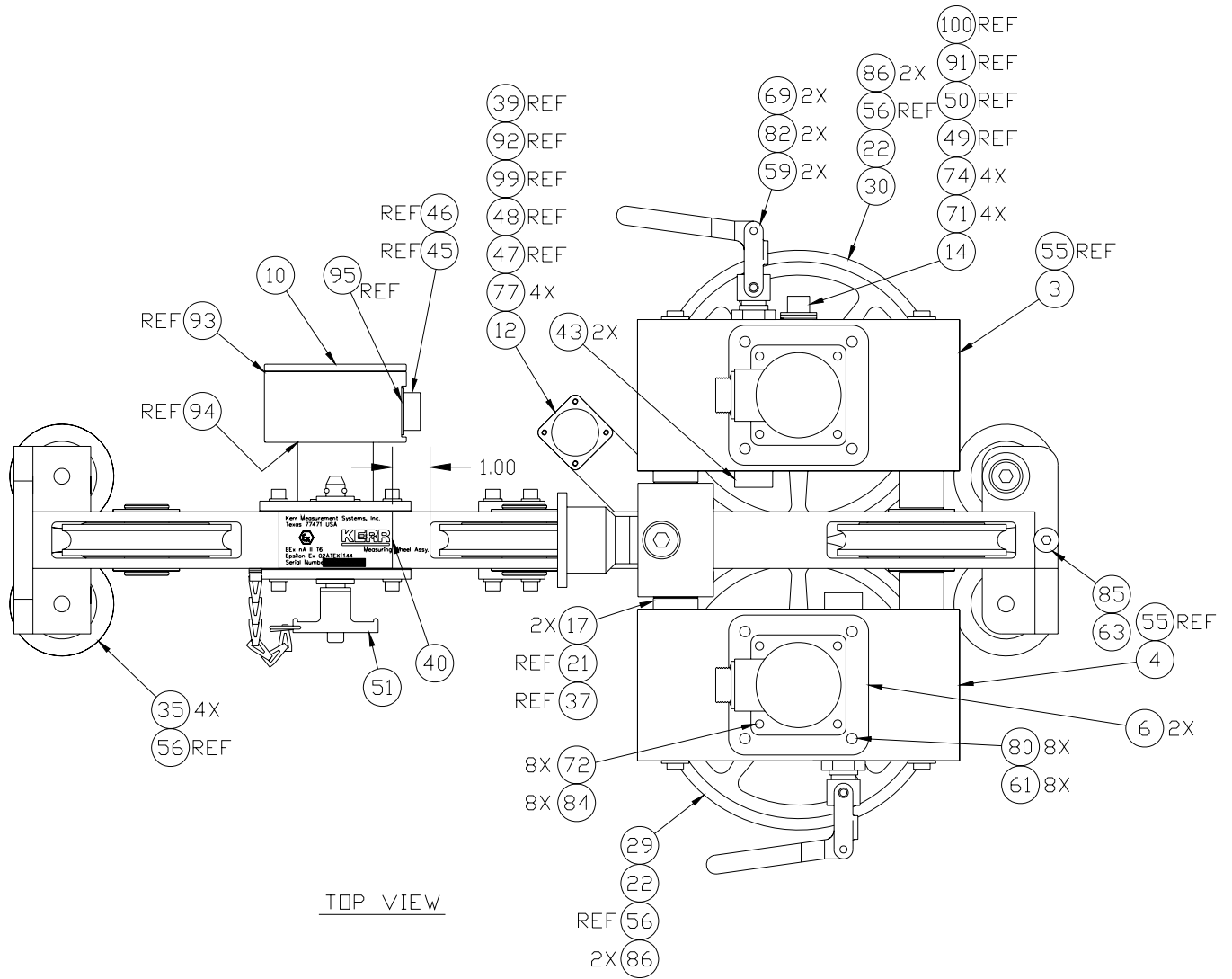

## FRONT VIEW

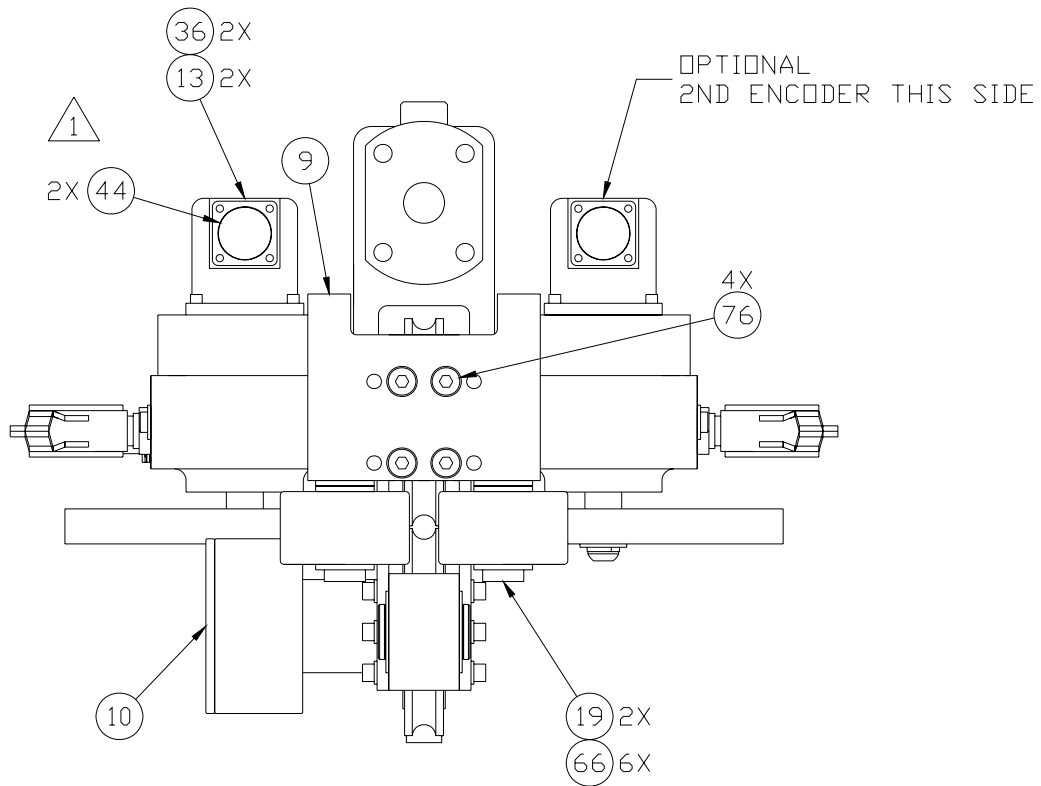

## REAR VIEW

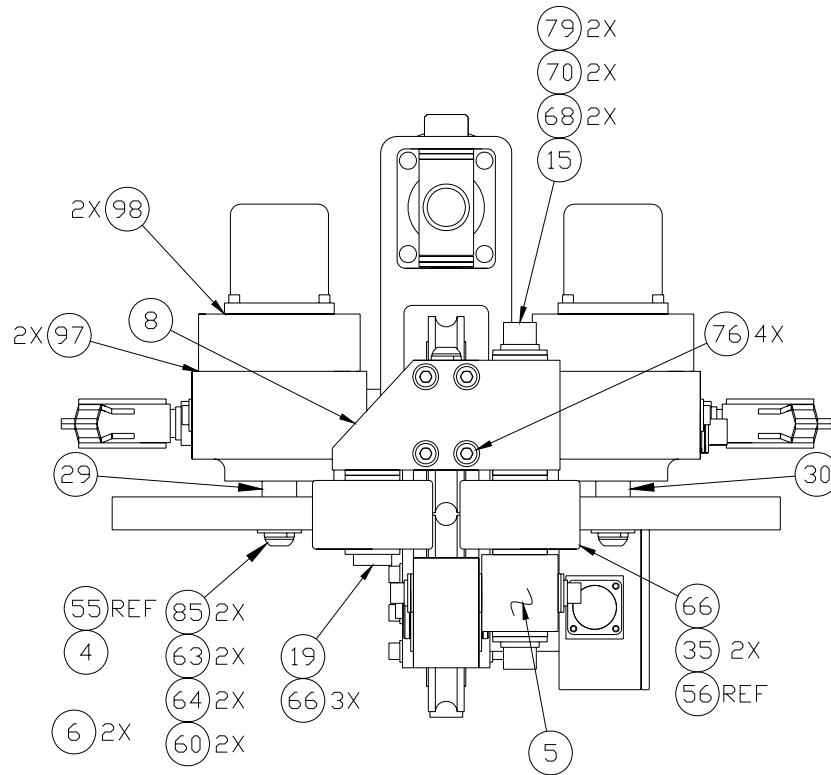

## PARTS LIST

ITEM	PART NUM	DESCRIPTION	QTY	REF
1	AM5KA131	ASSY FRAME BACKBONE UPPER 5WHL	1	
2	AM5KA232	ASSY FRAME BKBN LWR 5WHL GII	1	
3	AM5KA052-1	ASSY MOUNT FLTNG ENCDR WHL W/	1	OPTION W/MAG BACKUP
4	AM5KA052-2	ASSY MOUNT FLTNG ENCDR WHL W/O	1	
5	AM5KA053	ASSY BLOCK PIVOT HORIZ/VERT	1	
6	AM5KM057	ADAPTER ENCODER H37C/H25D	2	OPTION
6	AM5KM058	COVER ENCODER ADAPTER	1	OPTION
7	AM5KM020	ENDCAP FLOATING ENCODER MOUNT	4	
8	AM5KA057	ASSY MOUNT SPOOLNG ROLLER FRNT	1	
9	AM5KM026	MOUNT SPOOLING ROLLER REAR	1	
10	AMTKA012	ASSY LOAD AXLE 4-20MA ½ DIA	1	
11	AM5KA040	ASSY MOUNT CENTER YOKE 5 WHEEL	1	OPTION
12	AM5KA039	ASSY MMD FLAT HOUSING	1	OPTION
13	AMSLP061	ENCODER HD2.5D-0-SS-37F-1200-	2	
13	AM5KP189	ENCODER HD2.5D-0-SS-37F-300	2	OPTION
14	AM5KA055	ASSY ENCODER BACKUP MAGNETIC	1	OPTION
15	AM5KM024	SHAFT PIVOT VERTICAL 20MM SST	1	
16	AM5KM011	SHAFT TENSION ROLLER 30MM SST	5	
17	AM5KA059	ASSY SHAFT ENCODER SLIDE 30MM	2	
18	AM5KM023	SHAFT PIVOT HORIZONTAL 1/2 SST	1	
19	AM5KM013	SHAFT SPOOLING ROLLER 20MM	3	
20	AM5KP023	BOLT SHOULDER 3/4 X 3 SST	1	
21	AM5KP002	SPRING EXT 4" OAL 47/64 DIA SST	4	
22	AM5KM001	WHEEL MEASURING 2FT 5 SPOKE	2	
23	AM5KM141	ANCHOR SPRING 1/2" FLOATING	4	
24	AM5KM034	PLATE WEAR 1/16 X 1.5 X 3.5	1	
25	AM5KM049	BLOCK WEAR 1.50 X 1.50 X 0.56 TOOLSTL	2	LARGE LINES
25	AM5KM074	BLOCK WEAR UPPER TOOL STL CH	1	SMALL LINES ONLY
26	AM3KM134	BLOCK WEAR 0.75 X 2.50 TOOLSTL	2	
27	AM5KM159	BLOCK GUIDE TENSION WHEEL PLAS	2	
28	AM5KM084	SCREW ANTI-ROTATION TENS WHEEL	6	
29	AM5KM010	SHAFT WHEEL CANTILEVERED 5 WHL	1	
30	AM5KM060	SHAFT WHEEL CANTLVRD MAG 5 WHL	1	OPTION W/MAG BACKUP
31	AM5KA137	ASSY WHEEL GUIDE PLAS 35MM BRG	4	
33	AM5KA063	ASSY WHEEL TENSN FLAT LOAD AXL	1	OPTION
33	AM5KA073	ASSY WHEEL TENSN GRV LOAD AXLE	1	OPTION (HI TENSION)
34	AM5KA164	ASSY WHEEL TENSN FIXD 35MM BRG	2	
35	AM5KA065	ASSY ROLLER SPOOLNG 2.75" PLAS	4	
36	AM5KM073	COUPLING MOD ENCDR 0.250/0.375	2	OPTION
37	AM5KP124	PIN COILED SPRING 1/4 X 1-1/8	2	ENCODER SLIDE
38	AM5KP125	PIN COILED SPRING 3/16 X 1/2	1	TENSION WHEEL PIN
40	AM5KM099	LABEL SERIAL NUMBER KERR	1	
42	AM5KM138	YOKE PIVOT CENTER MOUNT SST	1	
43	AM5KM040	PUSHROD TOGGLE CLAMP PLASTIC	2	
51	AMS1P009	RETAINING PIN (T HANDLE)	1	

52	AMS1P072	PLUG 3/8 NPT SS	2	
53	AM5KP075	CHAIN SASH #35 SST	6	
54	AM5KM157	BEARING BALL 35MM ID MOD	6	
55	AM5KP088	BEARING LINEAR 30MMID X 40MMOD	8	
56	C276P002	BEARING BALL 20MM FAFNIR 204PP	4	
58	AM5KM134	BEARING BALL 40MM ID MOD	1	
59	AM5KP001	CLAMP TOGGLE PUSH/PULL SST	2	
60	AM5KM055	KEY 1/8 X 1/8 X 0.625L SST	2	
61	AM5KP144	WASHER 1/4 LOCK SS HIGH COLLAR	4	
62	ACMU2P31	WASHER 1/4 FLAT SS	8	
63	AMS1P058	WASHER 3/8 LOCK SS	3	
64	C276P513	WASHER 3/8 FLAT SST	2	
65	C276P036	WASHER 1/4 LOCK SS	4	
66	AM5KP011	WASHER 20MM FLAT SST	12	
67	C276P039	WASHER 5/16 FLAT SST	2	
68	AMS1P066	WASHER 1/2 LOCK SS	2	
69	AMS1P047	WASHER 5/16 LOCK SS	4	
70	C276P037	WASHER 1/2 FLAT SST	2	
71	C276P046	WASHER #6 LOCK SS	4	
72	C276P035	WASHER #10 LOCK SS	7	
73	AMS1P052	SCREW 10-24 X 5/8 SOC HD SST	4	
74	C276P331	SCREW 6-32 X 1/2 PHIL PAN SST	4	
75	AM5KP117	SCREW 1/4-20 X 5/8 BTN HD SST	4	
76	AM5KP038	SCREW 5/16-18 X 7/8 FH SOC SS	8	
77	AM5KP039	SCREW 10-24 X 7/8 FH SOC SST	2	
78	AM5KP040	SCREW 10-24 X 3/8 SOC HD SST	5	
79	AM5KP042	SCREW 1/2-13 X 3/4 SOC HD SST	2	
80	AMS1P048	SCREW 1/4-20 X 3/4 SOC HD SST	4	OPTION W/COVER
80	C276P031	SCREW 1/4-20 X 1-1/4 SOC HD SS	8	
82	AM5KP037	SCREW 5/16-18 X 4-1/2 SOC HD	2	
83	AM3KP028	SCREW 5/16-18 X 1/2 SHCS SST	2	
84	AMS1P053	SCREW 10-24 X 2 SHCS SST	8	OPTION W/HD ENCDR
85	AM5KP043	SCREW 3/8-16 X 1/2 BUTTON HD	3	
86	AMS1P006	RING RETNG INT UR187S	4	
87	AM5KP033	RING RETNG EXT 0.500 SHAFT SST	1	
89	AM3KP018	RING RETNG EXT 1.188 SHAFT SST	4	
90	AM5KP168	RING RETNG INT 2.875 LT DUTY	12	
91	C276P041	O-RING 2-017 BUNA N	1	BACKUP HSG
92	AM5KP072	O-RING 2-046 BUNA N MMD COVER	1	
93	C276P040	O-RING 2-235 BUNA N L/P LID	1	
94	AMS8P066	O-RING 2-136 BUNA N L/P HSG	1	
95	AM5KP118	O-RING 2-023 BUNA N L/P CONN	1	
96	AM5KP020	O-RING 2-030 BUNA N ENDCAP	4	
97	AMS1P014	O-RING 2-152 BUNA N ENC ADPTR	2	
98	AM5KP071	O-RING 2-141 BUNA N H25 ENCDR	2	
99	AM5KP119	O-RING 2-026 BUNA N MMD CONN	1	
100	C276P042	O-RING 2-016 BUNA N	1	BACKUP CONN
101	AM5KP130	NOZZLE GREASE FITTNG FLUSH	1	NOT SHOWN

## 6.2 MAGNETIC MARK DETECTOR SPECIFICATION

### 1. General

This specification describes the latest Kerr Measurement Systems magnetic mark detector

### 2. Mechanical

The mark detector will work in both the original housing p/n AMS1M022 and the AM5K versions using p/n AM5KM029. The pc board is potted to prevent damage from shock, vibration, or humidity.

### 3. Power

Input power is 9 - 30vdc at 100ma max.

### 4. Outputs

Digital line driver out for strong & strong\ and also weak & weak\ where a weak mark is 4 gauss or less and a strong mark is greater than 4.1 gauss measured 0.10 inch from cable surface. The signals are a +5vdc digital pulse. A digitized 0-5vdc representation of the analog signal is provided.

### 5. Performance

- a) Operating temperature -40 to +120 f. compensated and stable. Storage temperature -60 to +180 f.
- b) Magnetic mark detection at cable line speeds of 1 to 1000 feet per minute.
- c) Auto cal feature removes offset of the electronics and any constant magnetic field less than 1 gauss every 100ms. If in a greater field, it will auto calibrate every 11 seconds.
- d) Detection of apparent zero gauss (at high/low crossing) is within 0.1 inch and repeatable so as any error is not accumulative.
- e) Will survive a gauss level exposure of 60 gauss.

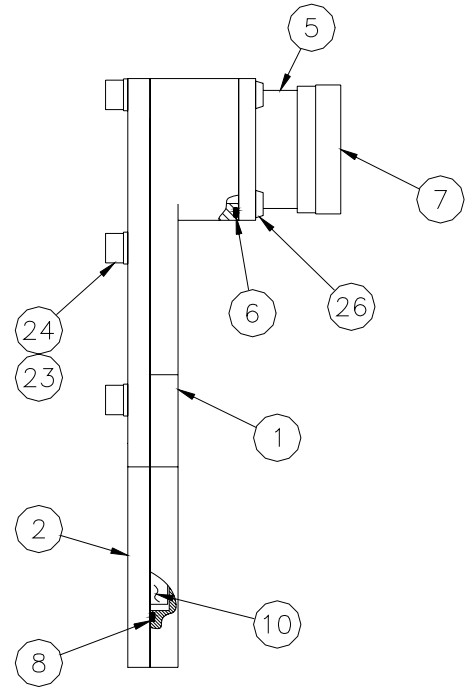
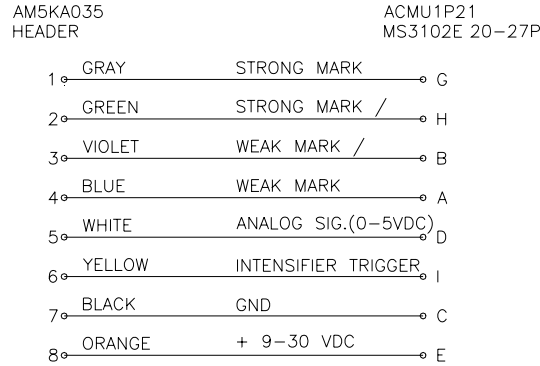
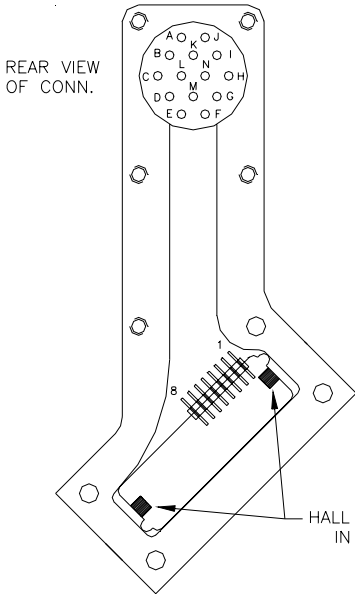

### AM5KA039 ASSY MMD

1	AM5KM029	ENCLSR MAGNETIC MARK DETECTOR	1	EA
2	AM5KM035	COVER MAGNETIC MARK DETECTOR	1	EA
5	ACMU1P21	CONN MS3102E-20-27P 14 PIN RECEPT	1	EA
6	AM5KP119	O-RING 2-026 BUNA N MMD CONN 1-1/4 X 1-3/8 X 1/16	1	EA
7	ACMU1P22	DUST CAP MS25D43-20DA	1	EA
8	AM5KP072	O-RING 2-046 BUNA N MMD COVER 4.239ID X 4.3790D X 0.070	1	EA
10	AM5KA035	PCB MMD POTTED, AM5K OR AMS100	1	EA
23	C276P035	WASHER #10 LOCK SS	5	EA
24	AMS8P029	SCREW 10-24 X 1/2 SOC HD SST	5	EA
26	AMS1P040	SCREW 6-32 X 3/8 PAN HD SST	4	EA

### 6.3 LOAD PIN

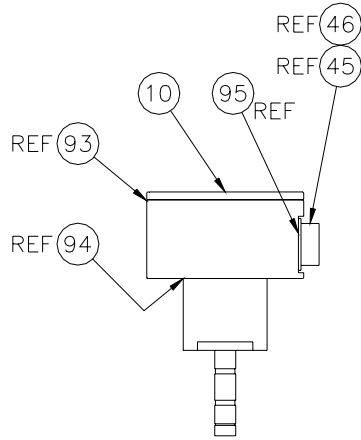

### AMTKA010 ASSY LOAD AXLE 1.5 V DIFFERENTIAL

45	AMS8P055	CONN KPT 02A16-8P	1 EA
46	AMS8P056	DUST CAP KPT81-16C	1 EA
93	C276P040	O-RING 2-235 BUNA N L/P LID 3-1/8 X 3-3/8 X 1/8	1 EA
94	AMS8P066	O-RING 2-136 BUNA N L/P HSG 1.98ID X 2.19OD X 0.103W	1 EA
95	AM5KP118	O-RING 2-023 BUNA N L/P CONN 1-1/16 X 1-3/16 X 1/16	1 EA



## 6.4 HI RESOLUTION ENCODER

### AMSLP061 ENCODER HD2.5D-0-SS-37F-1200 SPECIAL ETI

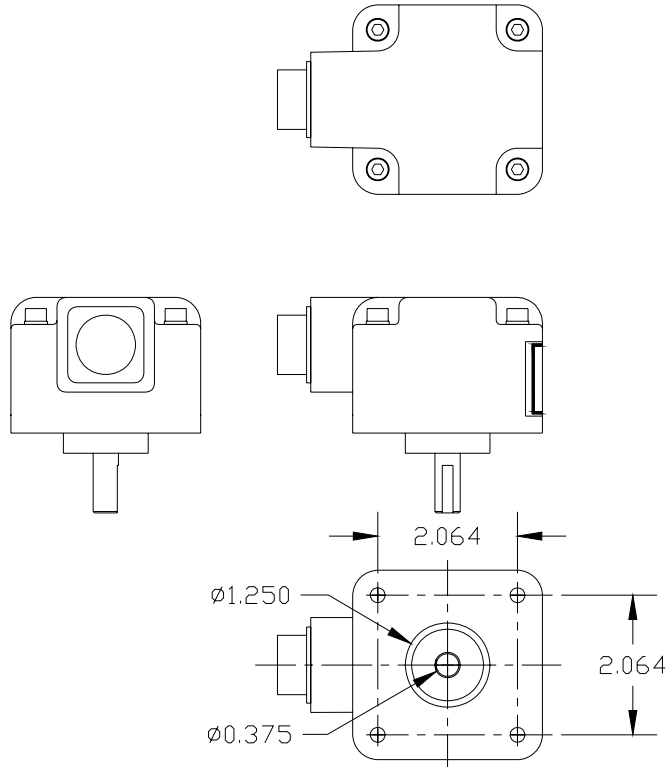

### Specifications

**1200 Pulses per revolution**

**5 – 15 vdc power**

**Differential Quadrature output (A & A not, B & B not)**

**MS3102R18S-1P 10 pin connector (pins)**

### Pin Out

A	-	A
H	-	A\
B	-	B
I	-	B\
D	-	+ 5v – 15 vdc
F	-	Gnd
G	-	Case

13	AMSLP061	ENCODER H25D-SS-1200-ABC-4469	1 EA
36	AM5KM073	COUPLING MOD ENCDR 0.250/0.375 BORE	1 EA
44	ACMU2P09	DUST CAP MS25043-18DA	1 EA

## 6.5 MEDIUM RESOLUTION ENCODER

### AM5KP189 ENCODER HD2.5D-0-SS-37F-1200 SPECIAL ETI

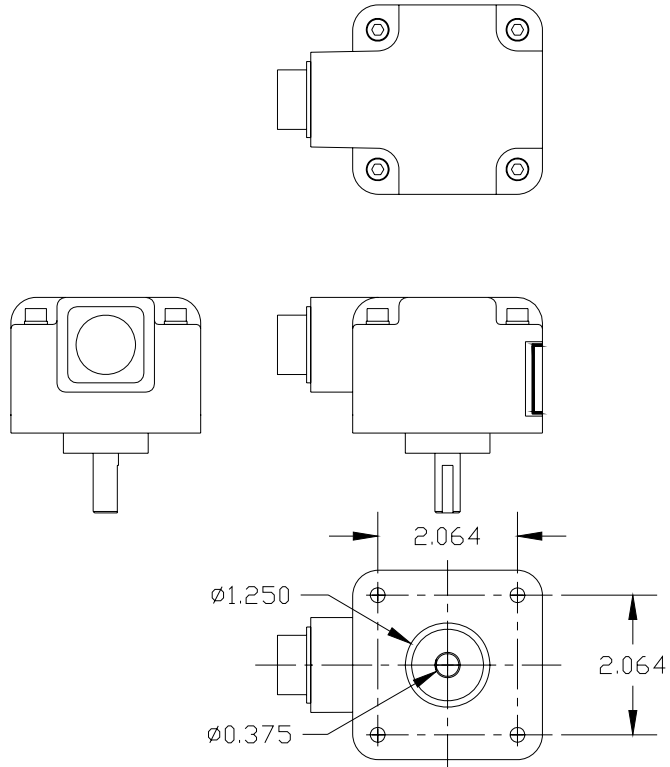

### Specifications

**300 Pulses per revolution**

**5 – 15 vdc power**

**Differential Quadrature output (A & A not, B & B not)**

**MS3102R16S 7 pin connector (pins)**

### Pin Out

A	-	A
B	-	B
C	-	A\
E	-	B\
D	-	+ 5v – 15 vdc
F	-	Gnd
G	-	Case

13	AM5KP189	ENCODER H25D-SS-1200-ABC-4469	1	EA
36	AM5KM073	COUPLING MOD ENCDR 0.250/0.375 BORE	1	EA

## 6.6 BACKUP ODOMETER CABLE AND WIRING

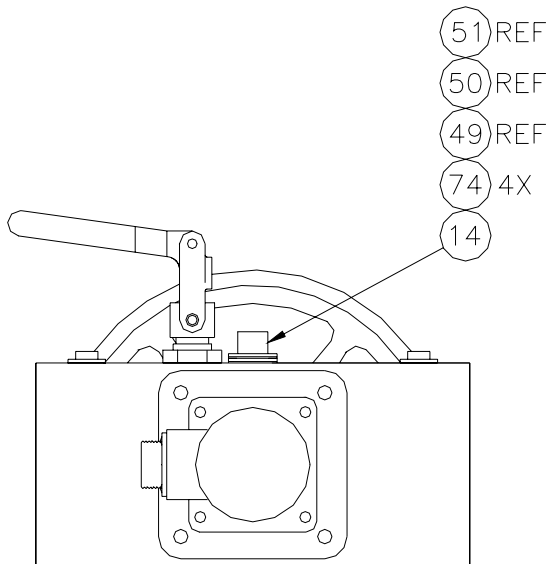

14	AM5KA058	ASSY ENCODER BACKUP MAGNETIC	1	EA
49	AM5KP027	CONN KPT02E10-6P RECEPTACLE MS3112	1	EA
50	AM5KP034	DUST CAP KPT8110C CANNON SHELL SIZE 10	1	EA
51	C276P041	O-RING 2-017	2	EA
74	AMS1P040	SCREW 6-32 X 3/8 PAN HD SST	4	EA

## AM5KA024-20 BACKUP ODOMETER CABLE

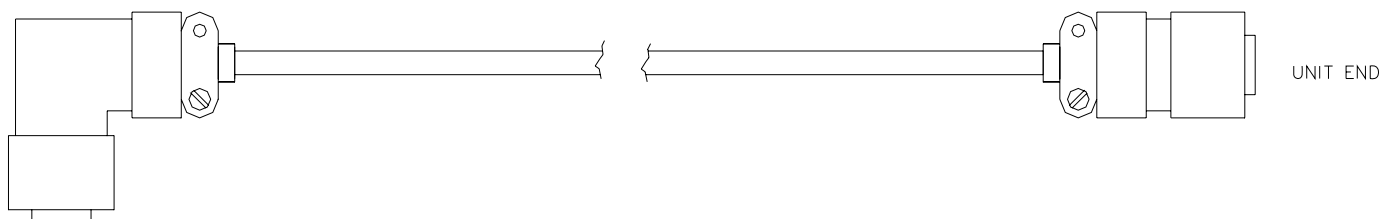

MEASURING HEAD END

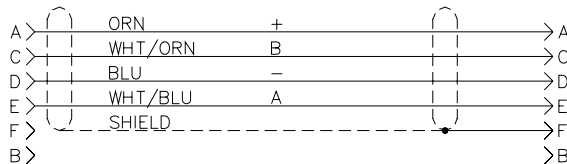

1	AMS7P062	CABLE 24/2P STNDED TC PE/PVC AL/MY SHLD W/DW NEC CMUL2919	20	FT
2	AM5KP057	CONN KPT06F10-6P STR PLUG	1	EA
3	AM5KP058	CONN KPT08F10-6S RT ANGLE PLUG	1	EA
4	AM5KP059	DUST CAP KPT8010C CANNON	2	EA
5	AM5KA034	BUSHING #9779-513-4 AMPHENOL	2	EA